



InfraRed Industrial Heat Incandescent

BR125 IR 150W E27 230-250V Red 1CT

The Philips infrared incandescent reflector lamps are designed to work in the toughest environment such as farm, bathroom or kitchen and their nearest surrounding. They have a reinforced construction thanks to hard glass use. Their compact form and universal cap base allow them to be used with any suitable equipment. A very good method of generating warmth is by using heat lamps. The Philips infrared lamps provide direct, draught-free warmth to the animals, people, but also food. These benefits have made farmers, consumers and cooks around the world choose Philips infrared lamps, because they are the sturdiest, most efficient lamps available for these applications.

Product data

• General Characteristics

Cap-Base	E27
Bulb	BR125
Bulb Material	Hard Glass
Bulb Finish	Red
Operating Position	h45
Main Application	Infrared Industrial
Average Lifetime	5000 hr

• Electrical Characteristics

Lamp Wattage	150 W
Voltage	230-250 V
Dimmable	Yes

• Luminaire Design Requirements

Pinch Temperature	250 (max) C
Bulb Temperature	250 (max) C

• Product Dimensions

Overall Length C	173 (max) mm
------------------	--------------

Diameter D 125 mm

• Product Data

Order code	923211843801
Full product code	923211843801
Full product name	BR125 IR 150W E27 230-250V Red 1CT
Order product name	BR125 IR 150W E27 230-250V Red 1CT/10
Pieces per pack	1
Packing configuration	10
Packs per outerbox	10
Bar code on pack - EAN1	8711500575203
Bar code on outerbox - EAN3	8727900209310
Logistic code(s) - 12NC	923211843801
Net weight per piece	104.000 gr

Dimensional drawing

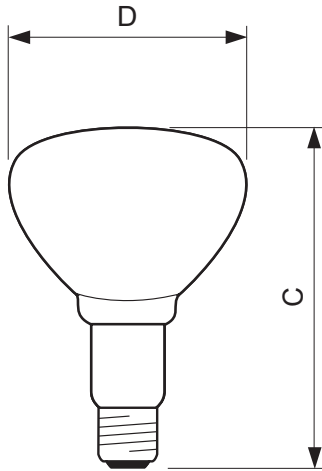

E27, BR125

Product	C (Min)	C (Norm)	C (Max)	D (Min)	D (Norm)	D (Max)
BR125 IR 150W E27 230-250V Red	-	-	173	-	125	-



E27



© 2011 Koninklijke Philips Electronics N.V.
All rights reserved.

Specifications are subject to change without notice. Trademarks are the property of Koninklijke Philips Electronics N.V. or their respective owners.

www.philips.com/lighting

2011, December 21
data subject to change